

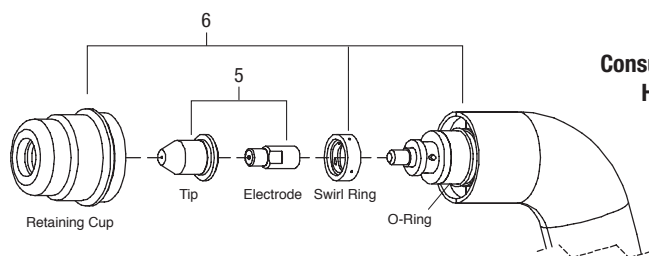

HP-25 Service Parts/Consumables

Item #	Part #	Description	Quantity
1	230 429	Handle Assy, left and right w/screws	1
2	232 081	Trigger Switch	1
3	230 432	Leads, 16 ft	1
4	230 430	Torch Head	1
5	770 496	Consumable kit, tip/electrode	1
6	770 497	Consumable kit, cup/swirl ring/o-ring	1
	233 321	Stand-off Guide	1
	233 046	Wrench	1

For a listing of original torch applications and replacements: **see pages 51–52**



Consumable Kits for
HP-25 Torch

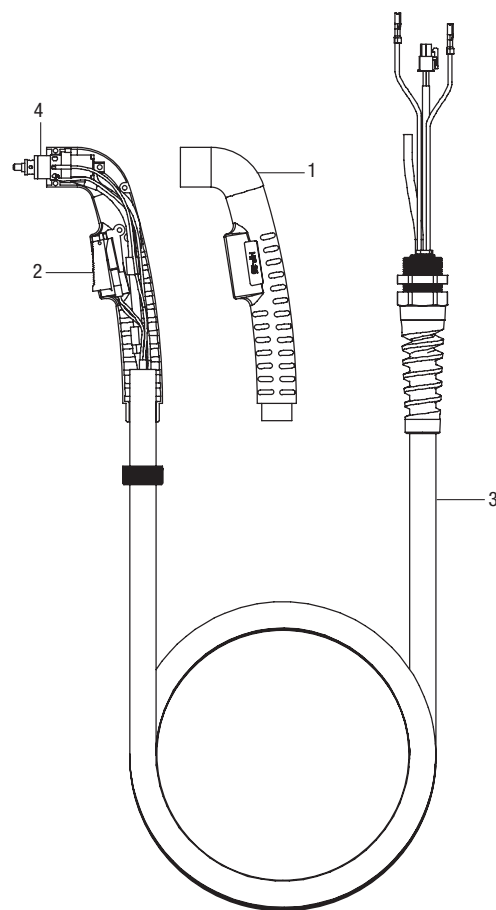

HP-25 Torch

HP-50 Service Parts/Consumables

Item #	Part #	Description	Quantity
1	770 496	Consumable kit, tip/electrode	2
2	770 653	Consumable kit, cup/swirl ring/O-ring	1
3	233 321	Stand-off guide, HP-25/50/70 plasma torch	1

For a listing of original torch applications and replacements: **see pages 51–52**

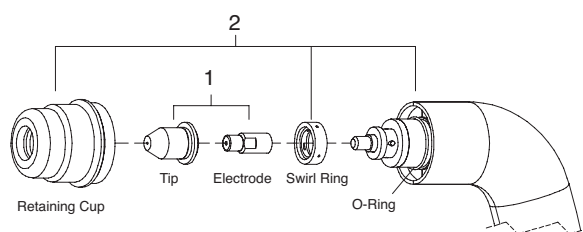

Consumable Kits for
HP-50 Torch

HP-70 Service Parts/Consumables

Item #	Part #	Description	Quantity
1	770 654	Consumable kit, tip/electrode	2
2	770 655	Consumable kit, cup/swirl ring/O-ring	1
3	233 321	Stand-off guide, HP-25/50/70 plasma torch	1

For a listing of original torch applications and replacements: **see pages 51–52**

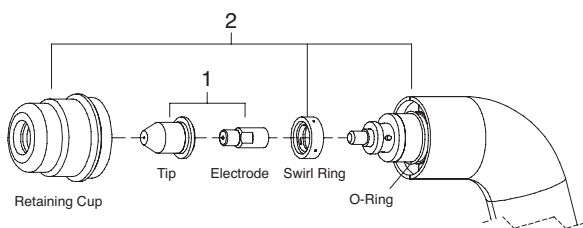

Consumable Kits for
HP-70 Torch