

M-Series MIG Guns

Model	Stock #	Length	Rating and Duty Cycle (CO ₂) ¹	Wire Size
M-100	248 282	10 ft (3 m)	100 A at 100% Duty Cycle	.030-.035 in (0.8-0.9 mm)
	220 606 ²			
M-150	249 039	10 ft (3 m)	150 A at 100% Duty Cycle	.030-.035 in (0.8-0.9 mm)
	249 040	12 ft (3.7 m)		
	249 041	15 ft (4.6 m)		
M-25	169 594	10 ft (3 m)	250 A at 100% Duty Cycle	.030-.035 in (0.8-0.9 mm)
	169 596	12 ft (3.7 m)		
	194 805 ³	12 ft (3.7 m)		
	169 598	15 ft (4.6 m)		
	169 599	15 ft (4.6 m)	250 A at 100% Duty Cycle	.035-.045 in (0.9-1.2 mm)
M-40	169 602 (N/A)	10 ft (3 m)	400 A at 100% Duty Cycle	.035-.045 in (0.9-1.2 mm)
	169 604 (N/A)	12 ft (3.7 m)		
	169 606 (N/A)	15 ft (4.6 m)		

¹60% with mixed gases

²#220 606 is an M-10 gun with friction terminals for the Miller Cricket.[®]

³#194 805 is an M-25 gun with friction lugs for the Hobart Beta-MIG 2510.

Miller MIG Gun History

Machine	Serial Number Effective	Original Gun	Recommended Replacement Gun
SideKick™	All Serial Numbers	GA-16C	M-100, pg 19
Cricket [®]	All Serial Numbers	GA-16C1	M-100 w/friction terminals, pg 19
SideKick™ XL/Cricket [®] XL/ Millermatic [®] 90	All Serial Numbers	GA-17C	M-100/M-150, pg 19
Millermatic [®] 35	Prior to JA448186	Original 058 260 Gun	N/A
	Effective with JA448186	GA-20C	M-150, pg 19
Millermatic [®] 120/150	Prior to KF849783	GA-17C	M-150, pg 19
	Effective with KF849783	M-15, pg 19	
Millermatic [®] 130	Prior to KF853420	GA-17C	M-100/M-150, pg 19
	Effective with KF853420	M-15, pg 19	
Millermatic [®] 130 XP	Prior to KK110539	10-A	M-100/M-150, pg 19
	Effective with KK110539	M-10, pg 19	
Millermatic [®] 135/140s/175/180s/DVI [®]	All Serial Numbers	M-10, pg 19	M-100/M-150, pg 19
Millermatic [®] Challenger™	All Serial Numbers	M-15, pg 19	M-100/M-150, pg 19
Millermatic [®] Challenger™ 172	Prior to KK118238	10-A	M-100/M-150, pg 19
	Effective with KK118238	M-10, pg 19	
Millermatic [®] 185	All Serial Numbers	M-15, pg 19	M-150, pg 19
Millermatic [®] 200	All Serial Numbers	GA-20C	M-25, pg 20
Millermatic [®] 210/212/250X/251/252	All Serial Numbers	M-25, pg 20	M-25, pg 20
	Prior to KF851980	GA-21C	M-25, pg 20
Millermatic [®] 250	Effective with KF851980	M-25, pg 20	
	All Serial Numbers	GA-20C; GA-21C; M-25, pg 20	M-25, pg 20
Millermatic [®] 300	All Serial Numbers	M-40, pg 21	Roughneck [®] , pg 25
Millermatic [®] 300 without Gun	All Serial Numbers	No Gun Included	Roughneck [®] , pg 25
Millermatic [®] 350	Prior to LE443589	Roughneck [®] 4012, pg 23	Roughneck [®] 4012, pg 25
	Effective with LE443589	Q3015AE8XM	Q3015AE8XM
Millermatic [®] Passport™ / Passport™ Plus	All Serial Numbers	M-10, pg 19	M-100, pg 19
Millermatic [®] Pulsar	All Serial Numbers	M-15, pg 19 and Spoolmate™ 3035, pg 39	M-150, pg 19 and Spoolmate™ 3035, pg 39



MIGmatic™ M-Series
100–250 Amp, Semi-Automatic,
Air-Cooled MIG Welding Guns

MIG Gun Holder #229 614



M-Series Consumable Kits (#234 607, #234 608, #234 609)
contain 10 contact tips, 1 nozzle and 1 contact tip adapter.



M-Series Consumable Kits (#234 610, #234 611, #234 612)
contain 10 contact tips, 1 nozzle, 1 contact tip adapter and 1 nozzle adapter.

Accessories

For a complete listing of gun consumables information, please refer to pages 19–22.

M-Series MIG Consumable Kits

To better serve you, Miller has introduced six improved, affordable MIG consumable kits that are compatible with the M-Series guns. Each kit contains consumables that are specific to your welding application, including gun type and wire size.

- 234 607–M-10/15, M-100/150 Gun, .023" Wire
- 234 608–M-10/15, M-100/150 Gun, .030" Wire
- 234 609–M-10/15, M-100/150 Gun, .035" Wire
- 234 610–M-25 Gun, .030" Wire
- 234 611–M-25 Gun, .035" Wire
- 234 612–M-25 Gun, .045" Wire

Aluminum Conversion Kit #172 136

For M-25 and M-40 only. Allows 10 ft guns to feed 3/64 in (1.2 mm) aluminum wire.



M-10/M-15 Service Parts/Consumables

Item #	Part #	Description	Quantity	
			M-10	M-15
1	169 715 ^(B)	Nozzle, slip type, .500 (12.7 mm) orf flush	1	1 (2 per pkg)
	226 190	Nozzle, slip type, flux cored	1	1
2	087 299 ^(B)	Tip, contact scr, .023 (0.6 mm) wire x 1.125	1	1 (10 per pkg)
	000 067 ^(B)	Tip, contact scr, .030 (0.8 mm) wire x 1.125	1	1 (10 per pkg)
	000 068 ^(B)	Tip, contact scr, .035 (0.9 mm) wire x 1.125	1	1 (10 per pkg)
	000 069 ^(B)	Tip, contact scr, .045 (1.2 mm) wire x 1.125	1	1 (10 per pkg)
3	169 716	Adapter, contact tip	1	1 (2 per pkg)
4	170 470	Ring, retaining	1	1
5	169 718	Tube, head	1	1
6	169 738	Nut, locking handle	1	2
7	169 719	Nut, jam (gun end)	1	1
8	169 737	Handle	1	2
9	169 741	Strain Relief, cable	—	2
10	227 800	Cord	1	1
11	209 495	Connector, feeder—M-10 (includes)	1	—
11	209 486	Connector, feeder—M-15 (includes)	—	1
12	079 974	O-Ring, .500 ID x .103CS rbr	2	2
13	194 010	Kit, liner monocoil .023/.025 (0.6 mm) wire x 15 ft (includes)	1	1
	194 011	Kit, liner monocoil .030 - .035 (0.8–0.9 mm) wire x 15 ft (includes)	1	1
14	079 975	O-Ring, .187 ID x .103CS rbr	1	1
15	227 798	Switch, trigger	1	1
16	079 878	Housing Plug and Pins	1	—
	079 531	Connector, circ cpc clamp str rlf	1	—
17	169 736	Terminal Block	—	1

^(B)Available in bulk quantities — see page 22 for more information.

M-10 can be used on:*

- SideKick™
- SideKick™ XL/Cricket® XL/Millermatic® 90
- Millermatic® 130
- Millermatic® 130 XP
- Millermatic® 135/140s/175/180s/DVI®/211
- Millermatic® Challenger™
- Millermatic® Challenger™ 172
- Millermatic® Passport™/Passport™ Plus

M-15 can be used on:*

- SideKick™ XL/Cricket® XL/Millermatic® 90
- Millermatic® 35
- Millermatic® 120/150
- Millermatic® 130
- Millermatic® 130 XP
- Millermatic® 135/140s/175/180s/DVI®/211
- Millermatic® Challenger™
- Millermatic® Challenger™ 172
- Millermatic® 185
- Millermatic® Pulser

*For a detailed listing, please reference page 18.

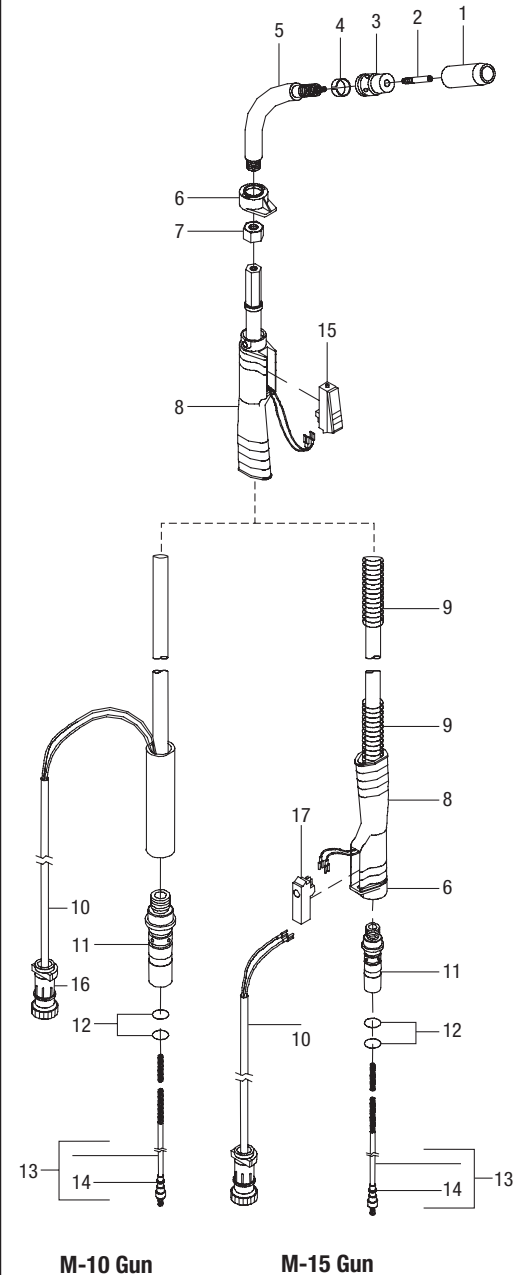

M-10 Gun

M-15 Gun

M-100/M-150 Service Parts/Consumables

Item #	Part #	Description	Quantity	
			M-100	M-150
1	246 372	Nozzle, slip type, .500 (12.7 mm) orf flush	1	1 (2 per pkg)
	226 190	Nozzle, slip type, flux cored	1	1
2	087 299 ^(B)	Tip, contact scr, .023 (0.6 mm) wire x 1.125	1	1 (10 per pkg)
	000 067 ^(B)	Tip, contact scr, .030 (0.8 mm) wire x 1.125	1	1 (10 per pkg)
	000 068 ^(B)	Tip, contact scr, .035 (0.9 mm) wire x 1.125	1	1 (10 per pkg)
	000 069 ^(B)	Tip, contact scr, .045 (1.2 mm) wire x 1.125	1	1 (10 per pkg)
3	170 470	Ring, retaining	1	1
4	169 716	Adapter, contact tip	1	1 (2 per pkg)
5	246 373	Tube, head	1	1
6	243 865	Nut, jam	2	2
7	246 082	Handle	1	1
8	246 376	Switch, trigger	1	1
9	079 878	Housing Plug and Pins	1	1
10	224 833	Connector, feeder	1	1
11	079 974	O-Ring, .500 ID x .103CS rbr	2	2
12	194 010	Kit, liner monocoil .023/.025 (0.6 mm) wire x 15 ft (includes)	1	1
	194 011	Kit, liner monocoil .030-.035 (0.8-0.9 mm) wire x 15 ft (includes)	1	1
	194 012	Kit, liner monocoil .035-.045 (0.9-1.2 mm) wire x 15 ft (includes)	1	1
13	079 975	O-Ring, .187 ID x .103CS rbr	1	1
14	246 380	Housing, power pin	1	1

^(B)Available in bulk quantities — see page 22 for more information.

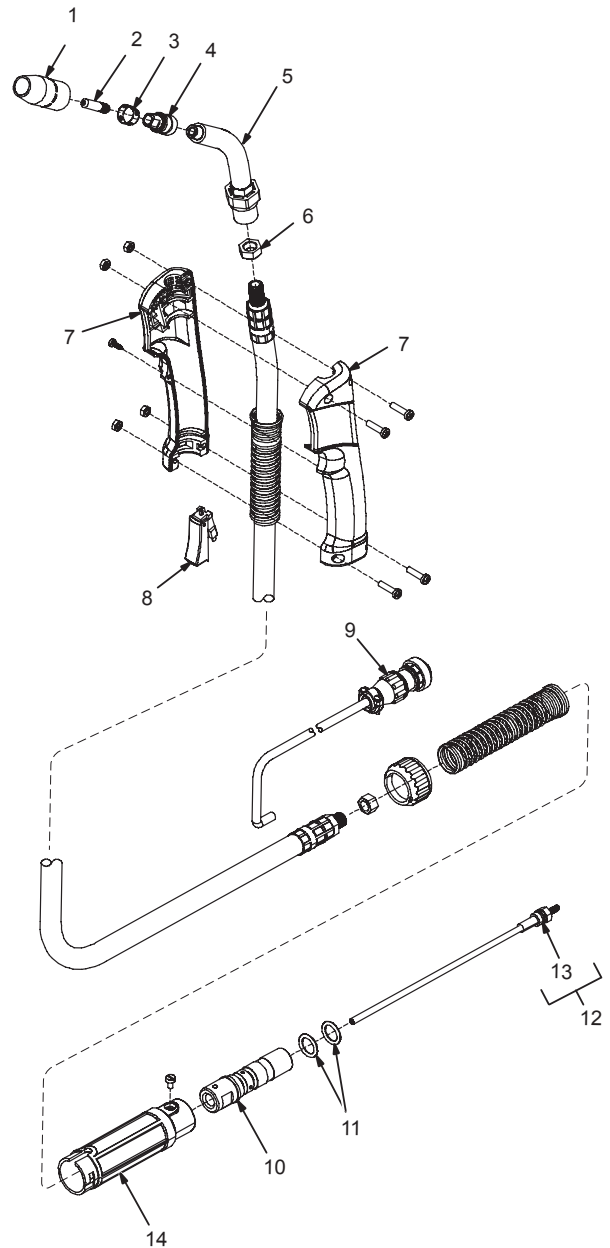

M-100 can be used on:*

- SideKick™
- SideKick™ XL/Cricket® XL/Millermatic® 90
- Millermatic® 130
- Millermatic® 130 XP
- Millermatic® 135/140s/175/180s/DVISM/211
- Millermatic® Challenger™
- Millermatic® Challenger™ 172
- Millermatic® Passport™/Passport™ Plus

M-150 can be used on:*

- SideKick™ XL/Cricket® XL/Millermatic® 90
- Millermatic® 35
- Millermatic® 120/150
- Millermatic® 130
- Millermatic® 130 XP
- Millermatic® 135/140s/175/180s/DVISM/211
- Millermatic® Challenger™
- Millermatic® Challenger™ 172
- Millermatic® 185
- Millermatic® Pulser

*For a detailed listing, please reference page 18.



M-25

Service Parts/Consumables

Item #	Part #	Description	Quantity
1	169 724 ^(B)	Nozzle, slip type, .500 (12.7 mm) orf .125 recess	1
	169 725 ^{1(B)}	Nozzle, slip type, .625 (15.9 mm) orf .125 recess	1
	200 258	Nozzle, slip type, .500 (12.7 mm) orf flush	1
	169 726 ^(B)	Nozzle, slip type, .625 (15.9 mm) orf flush	1
	169 727	Nozzle, slip type, .625 (15.9 mm) orf .125 stickout	1
2	087 299 ^(B)	Tip, contact scr, .023 (0.6 mm) wire x 1.125	1 (10 per pkg)
	000 067 ^(B)	Tip, contact scr, .030 (0.8 mm) wire x 1.125	1 (10 per pkg)
	000 068 ^(B)	Tip, contact scr, .035 (0.9 mm) wire x 1.125	1 (10 per pkg)
	000 069 ^(B)	Tip, contact scr, .045 (1.2 mm) wire x 1.125	1 (10 per pkg)
	172 034 ¹	Tip, contact scr 3/64 (1.19 mm) wire x 1.125	1 (10 per pkg)
3	169 728 ^(B)	Adapter, contact tip	1 (2 per pkg)
4	169 729	Adapter, nozzle	1 (2 per pkg)
5	170 468	O-Ring	1
6	169 730	Washer, shock	1
7	169 731	Tube, head	1
8	169 738	Nut, locking handle	2
9	169 732	Nut, jam	1
10	169 737	Handle, front	1
11	227 799	Handle, rear	1
12	227 800	Cord, trigger assembly	1
13	209 495	Connector, feeder (includes)	1
14	079 974	O-Ring, .500 ID x .103CS rbr	2
15	194 010	Kit, liner monocoil .023/.025 (0.6 mm) wire x 15 ft (includes)	1
15	194 011	Kit, liner monocoil .030 - .035 (0.8 - 0.9 mm) wire x 15 ft (includes)	1
15	194 012	Kit, liner monocoil .035 - .045 (0.9 - 1.2 mm) wire x 15 ft (includes)	1
15	194 014 ¹	Kit, liner monocoil 3/64 (1.19 mm) aluminum wire x 15 ft (includes)	1
16	079 975	O-Ring, .187 ID x .103CS rbr	1
17	227 798	Switch, trigger	1
18	2520033	Cable strain relief 2 & 3	1
19	W11127-002	Screw	1

¹Included with #172 136 Kit, Aluminum Conversion .047 in (1.2 mm)

^(B)Available in bulk quantities — see page 22 for more information.

M-25 can be used on:*

- Millermatic® 200
- Millermatic® 210/212/250x/251/252
- Millermatic® 250
- Millermatic® Vintage
- Millermatic® Reach Wire Feeder

*For a detailed listing, please reference page 18.

